Nature and Properties of Light

Linda J. Vandergriff
Director of Photonics System Engineering
Science Applications International Corporation
McLean, Virginia

Light plays a vital role in our daily lives. It is used in compact disc (CD) players, in which a laser reflecting off a CD transforms the returning signal into music. It is used in grocery store checkout lines, where laser beams read bar codes for prices. It is used by laser printers to record images on paper. It is used in digital cameras that capture our world and allow pictures to be displayed on the Internet. It is the basis of the technology that allows computers and telephones to be connected to one another over fiber-optic cables. And light is used in medicine, to produce images used in hospitals and in lasers that perform eye surgery.

The generation, transport, manipulation, detection, and use of light are at the heart of photonics. Photonics is a critical part of the future and a growing career field. In 1997 it was a \$50 billion market with a projected growth of 10 to 20 percent over the next decade. Photonics technicians and engineers must master new concepts, learn new techniques, and develop new skills. To work in photonics it is necessary to have a basic understanding of the nature of light and its properties.

Prerequisites

This module requires a basic understanding of high school algebra, trigonometry, general scientific nomenclature, the scientific process, units conversions, and basic concepts in elementary physics and chemistry.

Objectives

When you finish this module you will be able to:

- Describe the wide variety of opportunities for photonics technicians.
- Define and use basic radiometric units.
- Define the following properties of light:
 - Speed
 - Frequency
 - Wavelength
 - Energy
- Describe the dual nature of light, as a continuous wave and a discrete particle (photon), and give examples of light exhibiting both natures.
- Describe the six properties of electromagnetic waves and give everyday examples.
- Explain the mechanism that causes light to be polarized, explain the use of polarizing material, and give an example of the use of polarizers.
- Describe Huygens' principle and the superposition principle.
- Define the terms *reflection*, *refraction*, and *index of refraction* and explain how they are related.
- Explain diffraction and interference in terms of Huygens' principle.
- List the three types of emission and identify the material properties that control the emission type.
- Describe in a short paragraph the electromagnetic spectrum and sketch a diagram of the key optical regions and uses.
- Give a basic explanation of atoms and molecules and their ability to absorb, store, and emit quanta of energy.
- Define the primary equations describing the relationships between temperature of, wavelength of, and energy emitted by a blackbody and a graybody.
- Describe the mechanisms that affect light propagating in a medium and its transmission.

True Life Scenario

Holly works as a photonics assembly technician. The factory where she is employed creates laser diode assemblies for a variety of commercial uses. As an assembly technician, she creates and aligns laser diode components and ensures that the bonded products meet the tight quality standard she and her company require of all their products.

At the beginning of the shift, Holly gets her assignment for the production run. She prepares for entering the clean room where the work will take place. Then, after entering, she logs on at her assembly station. She selects the correct workspace file for the devices to be manufactured during that shift. The workspace file selection is based on wavelength, other optical properties, and pass/fail criteria set for this particular device.

With the components provided, Holly first sets up the lateral shearing interferometer and the microlens/laser diode product. Then she collimates and directs the laser diode beam into the beam analysis tool for testing.

After that she reviews the results on the computer monitor and adjusts the alignment until the device is acceptable. Finally, she bonds the microlens and laser diode and stores the final measurements to a log file on the network server. These measurements, along with those of the other devices created during this production run, will serve as a statistical base for evaluation of the production process and the product quality.

Holly will create a batch of microlens/laser diode pairs during her shift. Depending on the order and application, this run may require days or weeks. Then a new product will be designed for production, and Holly and her counterparts on the production floor will create it. This will require an evolving understanding of light and its uses to allow flexibility in the manufacturing process and keep Holly and her company competitive in the growing marketplace.



Figure 1-1 *Photonics assembly technician assembling LEDs¹*

Opening Demonstration

Note: The interactive exercise that follows is to be used as a short introduction to the wide range of photonics applications. It is intended to stimulate interest in the study of photonics.

Instructions: Create two or three groups. Have each group, with notes and manuals closed and without repeating, name a use of light technology. When no one in a group can think of a use that has not already been added to the list, that group drops out. Compare the groups' lists with the one following. Did the groups miss any areas? Are there any areas that should be on the following list but are not?

¹ Source: *Laser Focus World*, May 1999, 291. Reprinted by permission.

Photonics in Our Daily Lives

Home

- Energy-saving fluorescent lamps
- Infrared remote controls
- TV flat panel / large screen
- Optical fibers for cable TV
- Compact disc players
- IR motion sensors for home security
- Video disk players
- Alarm clock radio with LED display
- IR noncontact “ear” thermometers
- Infrared remote headphones

Office

- Optical scanners
- Fax machines
- Optical fiber telephone cables
- Optical data storage
- Laser printers
- Photocopiers
- Overhead slide projectors
- Video teleconferences
- Laser pointers
- Computer active matrix displays
- Computer displays
- Infrared remote connections
- Special optical computers

Car

- Infrared security systems
- Optical monitors for antilock brakes
- Optical fiber dashboard displays
- LED traffic signals
- Laser traffic radar
- Solar-powered emergency services

Store

- Supermarket bar-code scanners
- Credit card holograms

Medical

- Laser surgery
- Medical diagnosis tools
- Microscopes

Manufacturing

- Laser welding and cutting
- Optical stereo-lithography
- Machine vision
- Image recognition for quality control
- Nondestructive testing
- Precision measurement
- Optical inspection of labeling and packaging
- Laser fabric cutting machines

Other

- Laser light shows
- Digital cameras
- Night vision goggles
- Missile guidance
- Laser weapons
- Surveillance cameras
- Surveying—alignment and range finders
- Computer-generated optical elements
- Art gallery holography exhibits

Basic Concepts

I. NATURE AND PROPERTIES OF LIGHT

A. Introduction to Photonics

Photonics is defined as the generation, manipulation, transport, detection, and use of light information and energy whose quantum unit is the photon.

Photonics is based on the science of optics and electronics. The origins of optical technology (photonics) date back to the remote past. Exodus 38:8 (ca 1200 BCE) tells of “the looking glasses of the women.” In the coming century, photonics promises to be a vital part of the information revolution.

To enable us to understand and apply photonics, it is necessary to have a basic understanding of the behavior and properties of light. This course focuses on these fundamentals of photonics and prepares you for an exciting future as a photonics technician.

B. Photonics Opportunities

There are ten broad areas of employment that are likely to need increasing numbers of photonics technicians:

- Medicine-biomedical
- Environmental
- Energy
- Transportation
- Defense
- Public safety
- Aerospace
- Computers
- Manufacturing with photonics and test and analysis
- Communication and information technology

Medicine has seen significant growth in the use of photonics devices in laser surgery and in noninvasive diagnostic tools. This growth translates into ever-growing opportunities for biomedical photonics technicians.

On the environmental front, photonics devices can measure the pollutants in our air and water remotely. Photonics devices can harness renewable energy from the sun, augment other energy sources, and preserve our natural resources. Transportation will be undergoing significant changes, such as the introduction of the Intelligent Vehicle Highway System, which provides guidance, collision avoidance, and continuous tuning of engines based on driving conditions.

The defense industry and public safety agencies need the ability to see and understand the environment, whether it is an enemy’s movement or a tornado’s path. The defense industry, in addition, has identified several photonics devices that can neutralize enemy weapons. These fields will grow and will provide significant potential for technicians who work in the areas of remote sensing, image processing, and high-energy laser operation.

In the Information Age, photonics will be essential in gathering, manipulating, storing, routing, and displaying information. New optical computers are proposed for some functions, and charged coupled devices (CCD) cameras digitize artwork. Compact discs, digital video devices (DVD), and other media are used for data storage and retrieval using lasers. The links between nodes of the Internet or telephone lines make use of fiber optics. Data can be printed with laser printers or displayed on plasma panels. This area of photonics application is growing at an incredible rate, and the potential for technicians who work in this area is very high.

Automation of manufacturing relies heavily on photonics. Fabrication is performed mainly by industrial lasers that cut, weld, trim, drill holes, and heat-treat products. To ensure product quality, inspection is performed using spectroscopy, interferometry, machine vision, and image processing. As manufacturing becomes more sophisticated in its use of photonics, the demand for skilled photonics technicians is expected to grow explosively.

C. Properties of Light

What is light? This question has been debated for many centuries. The sun radiates light, electric lights brighten our darkness, and many other uses of light impact our lives daily. The answer, in short, is light is a special kind of electromagnetic energy.

The speed of light, although quite fast, is not infinite. The speed of light in a vacuum is expressed as $c = 2.99 \times 10^8$ m/s. Light travels in a vacuum at a constant speed, and this speed is considered a universal constant. It is important to note that speed changes for light traveling through nonvacuum media such as air (0.03% slower) or glass (30.0% slower).

For most purposes, we may represent light in terms of its magnitude and direction. In a vacuum, light will travel in a straight line at fixed speed, carrying energy from one place to another. Two key properties of light interacting with a medium are:

1. It can be deflected upon passing from one medium to another (refraction).
2. It can be bounced off a surface (reflection).

The aspects of light interaction with media other than a vacuum will be addressed further in Modules 1.3 and 1.4, which deal with geometrical and physical optics, respectively.

The field of detection and measurement of light energy is called *radiometry*. It uses a standardized system for characterizing radiant energy. Table 1-1 defines the standard terms used in this course.

Table 1-1: Radiometric Definition and Units

Term	Definition	Symbol	Units
Quantity	Radiant energy	Q	Joule (J)
Flux	Rate of radiant energy	Φ	Watt (W); Joule/second (J/s)
Flux density (irradiance)	Flux per unit area	E	Watts per square meter (W/m^2)
Intensity	Flux per solid angle	I	Watts per steradian (W/sr)
Radiance	Flux per unit area per unit solid angle	L	Watts per square meter per steradian ($W/m^2 \cdot sr$)
Spectral radiance	Radiance per unit wavelength	L_λ	Watts per square meter per steradian per nanometer $\frac{W}{m^2 \cdot sr \cdot \Delta\lambda}$

Dual Nature of Light

Scientists build models of physical processes to help them understand and predict behavior. So it is with light energy. It is through seeing the effects of light that the models are developed. Scientists have observed that light energy can behave like a wave as it moves through space, or it can behave like a discrete particle with a discrete amount of energy (quantum) that can be absorbed and emitted. As we study and use light, both models are helpful.

Concept of a photon

The particle-like nature of light is modeled with photons. A photon has no mass and no charge. It is a carrier of electromagnetic energy and interacts with other discrete particles (e.g., electrons, atoms, and molecules).

A beam of light is modeled as a stream of photons, each carrying a well-defined energy that is dependent upon the wavelength of the light. The energy of a given photon can be calculated by:

Photon energy (E) = hc/λ	(1-1)
--------------------------------------	-------

where E is in joules

h = Planck’s constant = 6.625×10^{-34} J·s

c = Speed of light = 2.998×10^8 m/s

λ = Wavelength of the light in meters

Example 1-1

Photons in a pale blue light have a wavelength of 500 nm. (The symbol nm is defined as a nanometer = 10^{-9} m.) What is the energy of this photon?

Solution:

$$\begin{aligned}
 E &= hc / \lambda = [6.625 \times 10^{-34} \text{ J}\cdot\text{s} \times 2.998 \times 10^8 \text{ m/s}] / 500 \times 10^{-9} \text{ m} \\
 &= \frac{6.625 \times 10^{-34} \times 2.998 \times 10^8}{500 \times 10^{-9}} \\
 &= 3.97 \times 10^{-19} \text{ J}
 \end{aligned}$$

When ultraviolet light shines on some metal surfaces, it causes electrons to be emitted. This effect is shown in Figure 1-2. The *photoelectric effect* did not produce results that matched the early predictions of wave theory. Two concerns were:

1. More intense radiation (larger-amplitude waves) did not cause emitted electrons to have more energy.
2. The energy of the emitted electron was dependent on the wavelength of the light, not the amplitude of the wave.

In the photoelectric effect experiment shown in Figure 1-2, light strikes a metal plate. Electrons are immediately released. The flow of electricity in the external circuit can be measured and the number of electrons generated for a given light signal can be determined.

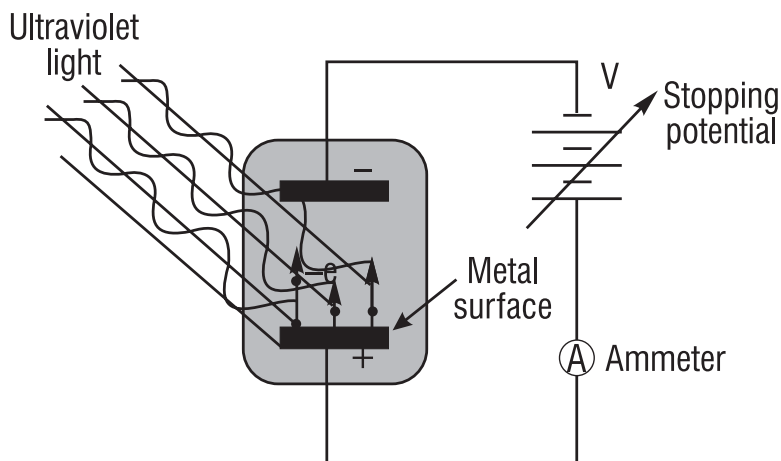

Figure 1-2 Photoelectric effect experiment

If light were a continuous wave, it might wash over the metal surface and interact with the electrons to give them the needed energy to escape at lower light levels (intensities), but only after long delays. However, faint light at high frequencies (short wavelengths) caused the immediate release of electrons. Thus, light knocked the electrons out of the metal surface as if the light were made of particles—*photons*.

There is a minimum energy threshold for an electron to escape from the metal. Photons with frequencies below a given threshold eject no electrons, no matter how intense the light. Photons with frequencies above the threshold do eject electrons, no matter how low the intensity. The energy of the released electrons can be calculated from Equation 1-2:

$$E_{e^-} = hc/\lambda - p \quad (1-2)$$

where: p = characteristic escape energy for the metal
 E_{e^-} = the kinetic energy of an escaping electron
 hc/λ = the energy of the photon of wavelength λ

Example 1-2

We can calculate the threshold wavelength of light needed to just release electrons from gold. This corresponds to E_{e^-} equal to zero. Solve Equation 1-2 for λ .

Solution:

Let $hc/\lambda = p$, so that

$$hc/p = \lambda$$

The escape energy for gold is $p_{\text{gold}} = 7.68 \times 10^{-19} \text{ J}$

$$\begin{aligned} \lambda &= \frac{6.625 \times 10^{-34} \text{ J}\cdot\text{s} \times 2.998 \times 10^8 \text{ m/s}}{7.68 \times 10^{-19} \text{ J}} \\ &= 2.59 \times 10^{-7} \text{ m or } 0.259 \mu\text{m} \end{aligned}$$

The photon model, although quite useful in explaining some properties of light, is still closely related to the wave model discussed below.

Wave Model

The particle-like model of light describes large-scale effects such as light passing through lenses or bouncing off mirrors (dealt with in Module 1-3, *Basic Geometrical Optics*). However, a wavelike model must be used to describe fine-scale effects such as interference and diffraction that occur when light passes through small openings or by sharp edges (dealt with in Module 1-4, *Basic Physical Optics*). The propagation of light or electromagnetic energy through space can be described in terms of a traveling wave motion. The wave moves energy—without moving mass—from one place to another at a speed independent of its intensity or wavelength.

This wave nature of light is the basis of physical optics and describes the interaction of light with media. Many of these processes require calculus and quantum theory to describe them rigorously. For this text it is sufficient to provide the resulting equations and models to be used by the photonics technician in real applications.

Characteristics of light waves

To understand light waves, it is important to understand basic wave motion itself. Water waves are sequences of crests (high points) and troughs (low points) that “move” along the surface of the water. When ocean waves roll in toward the beach, the line of crests and troughs is seen as profiles parallel to the beach. An electromagnetic wave is made of an electric field and a magnetic field that alternately get weaker and stronger. The directions of the fields are at right

angles to the direction the wave is moving, just as the motion of the water is up and down while a water wave moves horizontally. Figure 1-3 is a one-dimensional representation of the electric field.

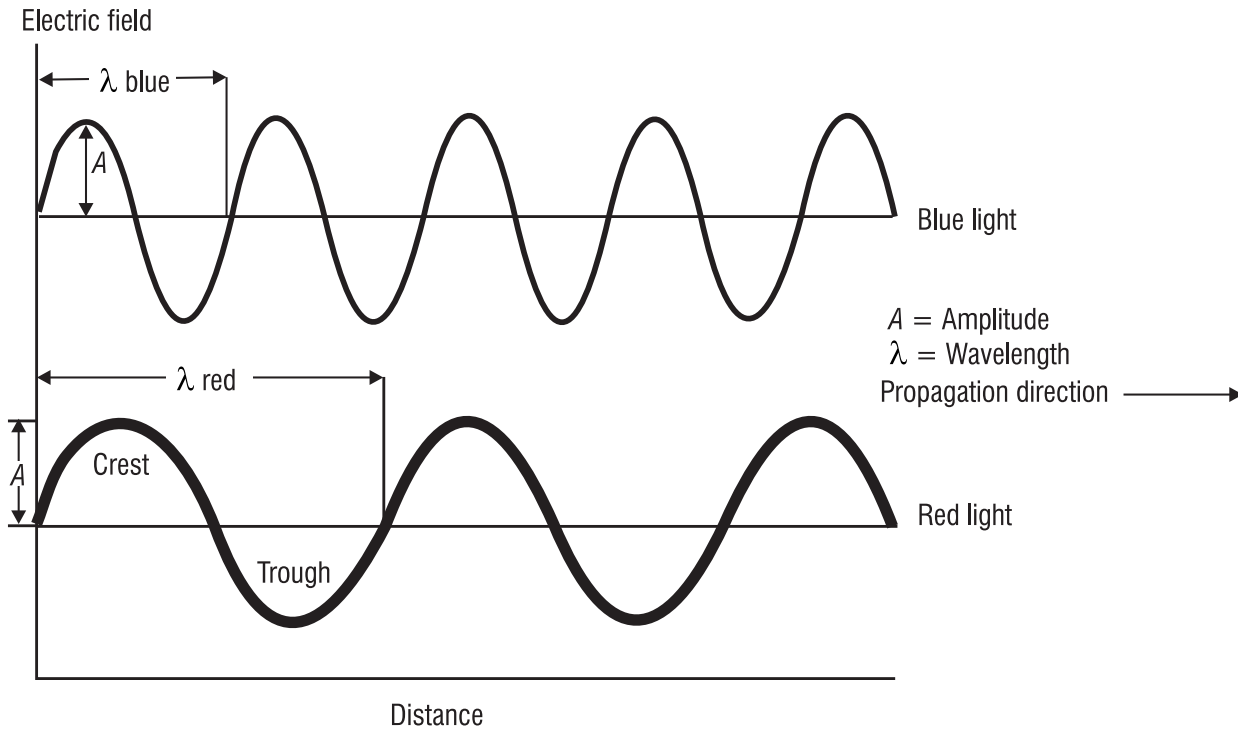

Figure1-3 One-dimensional representation of the electromagnetic wave

The maximum value of the wave displacement is called the **amplitude** (A) of the wave. The cycle starts at zero and repeats after a distance. This distance is called the **wavelength** (λ). Light can have different wavelengths, such as the blue light and red light shown in Figure 1-3. The inverse of the wavelength ($1/\lambda$) is the **wave number** (ν), which is expressed in cm^{-1} . The wave propagates at a **wave speed** (v). This wave speed in a vacuum is equal to c , and is less than c in a medium. At a stationary point along the wave, the wave passes by in a repeating cycle. The time to complete one cycle is called the **cycle time or period** (τ) and can be calculated using Equation 1-3.

$$\tau = \lambda/\nu \tag{1-3}$$

Another important measure of a wave is its **frequency** (f). It is measured as the number of waves that pass a given point in one second. The unit for frequency is cycles per second, also called hertz (Hz). As you can see, the frequency and the period are reciprocals of one another. If the wave speed and wavelength are known, the frequency can be calculated with Equation 1-4.

$$f = 1/\tau = \nu/\lambda \tag{1-4}$$

Example 1-3

For blue light in a vacuum, we can calculate the cycle time and frequency. From a previous example, we know that the wavelength of blue light is 500 nm and the velocity of light in a vacuum is c . Plugging in the numbers in Equation 1-3 we get:

$$\tau = \lambda/v = \frac{500 \times 10^{-9} \text{ m}}{2.998 \times 10^8 \text{ m/s}} = 1.667 \times 10^{-15} \text{ s}$$

Then we can calculate the frequency using Equation 1-4.

$$f = 1/\tau = 1/1.667 \times 10^{-15} \text{ s} = 5.996 \times 10^{14} \text{ Hz}$$

It is possible for a wave to have other than sinusoidal shapes; however, the important concept to remember is that light waves are transverse electric and magnetic fields changing in space and time and propagating at the speed of light in a given medium, as we show below.

Concept of light waves—Oscillating electric and magnetic fields

Light waves are complex. They are not one-dimensional waves but rather are composed of mutually perpendicular electric and magnetic fields with wave motion at right angles to both fields, as illustrated in Figure 1-4. The wave carries light energy with it. The amount of energy that flows per second across a unit area perpendicular to the direction of travel is called the irradiance (flux density) of the wave.

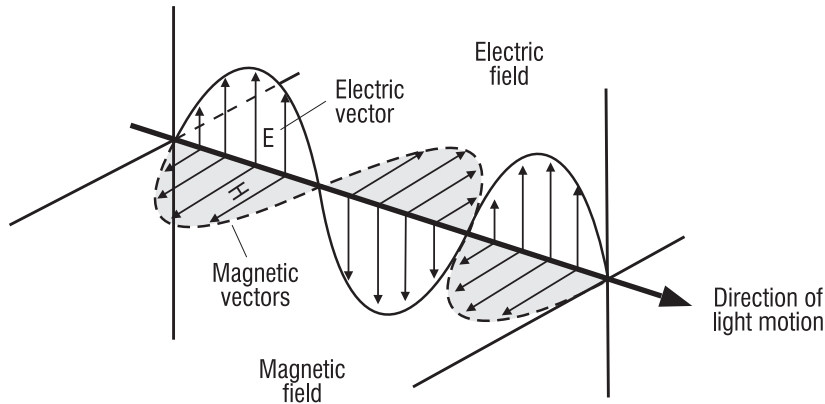

Figure 1-4 *Electric and magnetic fields in a light wave*

Electromagnetic waves share six properties with all forms of wave motion:

- Polarization
- Superposition
- Reflection
- Refraction
- Diffraction
- Interference

Polarization

Up to this point we have discussed the direction of light’s propagation and its associated electric and magnetic fields. Polarization arises from the direction of the E-field vector with respect to the direction of the light’s propagation. Since a light wave’s electric field vibrates in a direction perpendicular to its propagation motion, it is called a *transverse* wave and is polarizable.

A sound wave, by contrast, vibrates back and forth along its propagation direction and thus is not polarizable.

Light is *unpolarized* if it is composed of vibrations in many different directions, with no preferred orientation. See Figure 1-5(a). Many light sources (e.g., incandescent bulbs, arc lamps, the sun) produce unpolarized light. Vertically polarized light is shown in Figure 1-5(b) and horizontally polarized light in Figure 1-5(c). Each is an example of *linearly* polarized light.

Figure 1-5(d) shows linearly polarized light making an angle of θ with the vertical. In this case, the tilted E-vector can be described by its components, E_x and E_y .

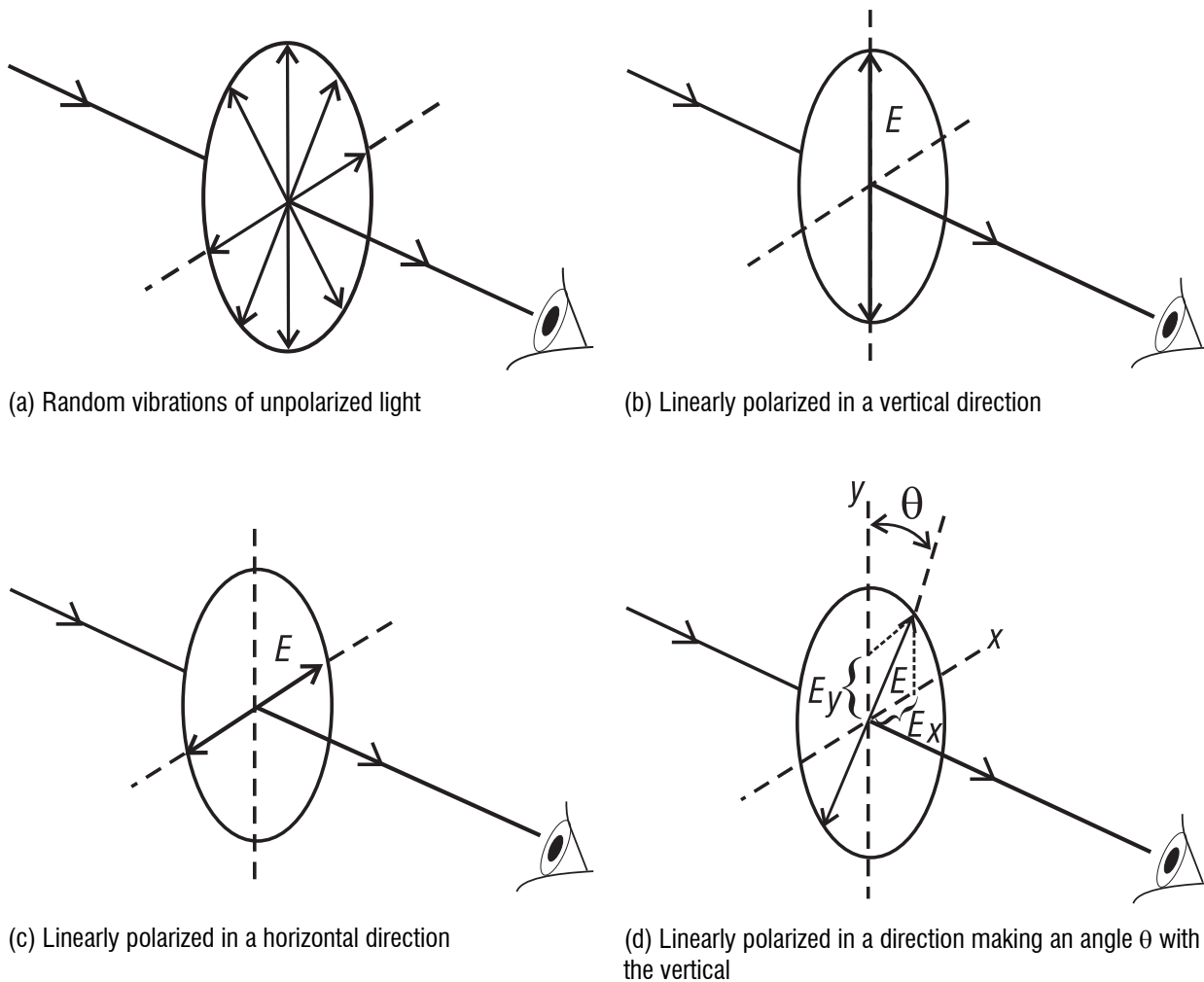

Figure 1-5 *Unpolarized and linearly polarized light*

NATURE AND PROPERTIES OF LIGHT

When it happens, as in some cases, that E_x and E_y are not in the same phase—that is, they do not reach their maxima and minima at the same time—the E -field does not remain oriented in a fixed, linear direction. Rather, the amplitude maxima of the two components do not occur at the same time and so-called *elliptically* polarized light is exhibited. This means that, over time, light exhibits differing polarization orientations. A special case of elliptical polarization—called *circular* polarization—occurs when E_x equals E_y and they are out of phase by 90° .

Certain materials will transmit only selected polarizations. They are called polarizers—or analyzers—and have many uses. With randomly polarized light, a polarizer will pass light of one polarization and absorb or reflect other polarizations. A common example of the use of polarization in our daily life is found in polarizing sunglasses. The material in the lenses passes light whose electric field vibrations are perpendicular to certain molecular alignments and absorbs light whose electric field vibrations are parallel to the molecular alignments. The major component of light reflecting from a surface, such as a lake or car hood, is horizontally polarized, parallel to the surface. Thus, polarization in sunglasses, with the *transmission axis* in a vertical direction, rejects horizontally polarized light and therefore reduces glare. However, if you consider a sunbather lying on his or her side, wearing such sunglasses, the usual vertical polarization (transmission axis) will now be at 90° and parallel to the surface and will therefore pass the horizontally polarized light reflected off the water or the land.

The intensity of light passing through a linear polarizer can be calculated using Equation 1-5.

$$I(\theta) = I_0 \cos^2 (\theta) \quad (1-5)$$

where $I(\theta)$ is the light intensity passed by the polarizer

I_0 is the incident light intensity.

The angle of the E -field with respect to the transmission axis is defined as θ .

Example 1-4

(a) Given horizontally polarized light, what would be the ratio of the light intensity output to the light intensity input for $\theta = 0^\circ$, 45° , and 90° ?

Solution: Use Equation 1-5 to solve for $I(\theta)/I_0$ and plug in the numbers.

$$I(\theta)/I_0 = \cos^2 (\theta)$$

$$I(0)/I_0 = \cos^2 (0) = 1$$

$$I(45)/I_0 = \cos^2 (45) = 0.5$$

$$I(90)/I_0 = \cos^2 (90) = 0$$

(b) Given two polarizers and incident vertically polarized light, what is the ratio of the resultant light intensity to the incident light intensity if the polarizers' transmission axes are both vertical and parallel? What is the ratio if the axes are crossed, that is, one vertical and one horizontal?

Solution: First, for the parallel polarizers, calculate the $I(\theta)/I_0$ for the first polarizer assuming θ is 0. Then take the ratio of the two and repeat for the second polarizer. The resulting ratio is 1. Now, for the perpendicular polarizers, calculate $I(\theta)/I_0$ for the first polarizer, assuming θ is 0. Then take

the ratio of the two and repeat for the second polarizer, this time assuming that θ is 90. The resulting value is 0, as should be expected from crossed polarizers.

Huygens' Principle

In the seventeenth century, Christian Huygens proposed a principle that can be used to predict where a given wave front will be at any time in the future if you know the current location. His principle assumes that each point along a wave front can be considered a point source for production of secondary spherical wavelets. After a period of time, the new position of the wave front will be the surface tangent to these secondary wavelets. Huygens' principle is illustrated in Figure 1-6, for five point sources on a wave front.

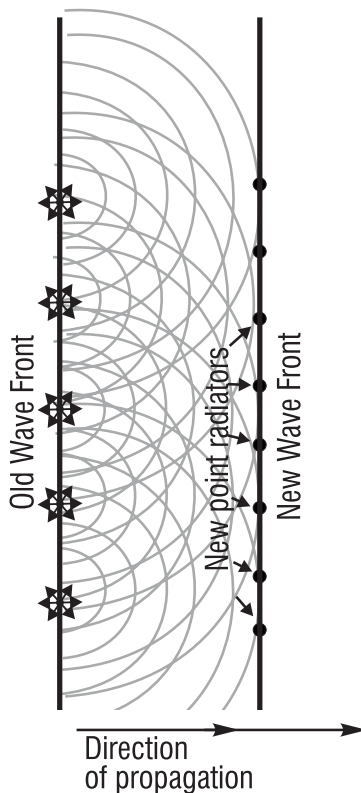

Figure 1-6 Using Huygens' principle to establish new wave fronts

Superposition

For many kinds of waves, including electromagnetic, two or more waves can traverse the same space at the same time *independently* of one another. This means that the electric field at any point in space is simply the vector sum of the electric fields that the individual waves alone produce at the point. This is the *superposition principle*. Both the electric and magnetic fields of an electromagnetic wave satisfy the superposition principle. Thus, given multiple waves, the field at any given point can be calculated by summing each of the individual wave vectors.

NATURE AND PROPERTIES OF LIGHT

When two or more waves are superimposed, the resulting physical effect is called interference. Suppose two waves, y_1 and y_2 , have nearly the same wavelength and phase (i.e., the maxima occur at nearly the same time and place). Superposition of these waves results in a wave ($y_1 + y_2$) of almost twice the amplitude of the individual waves. See Figure 1-7a. This is called constructive interference. If the maximum of one wave is near the minimum of the other wave, the resultant ($y_1 + y_2$) has almost no amplitude, as shown in Figure 1-7b. This is called destructive interference.

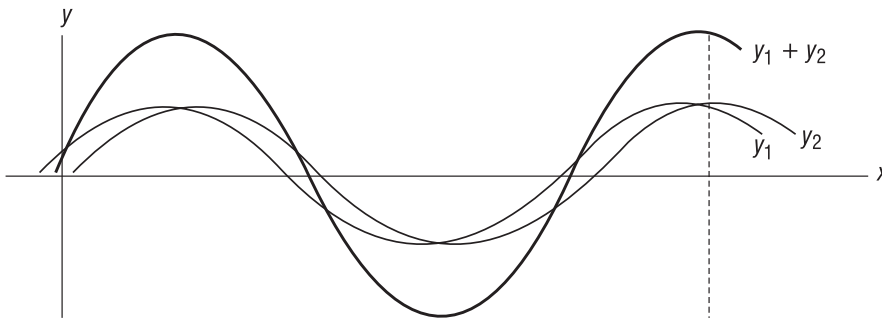

(a) Mostly constructive interference

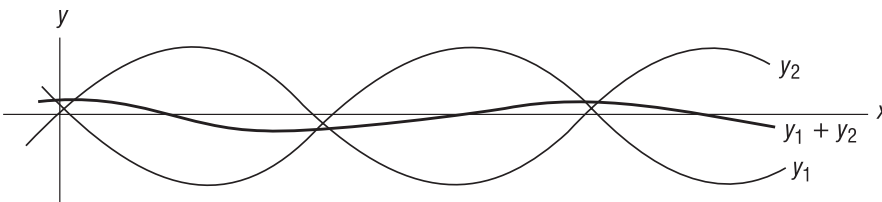

(b) Mostly destructive interference

Figure 1-7 Using the principle of superposition to add individual waves

Reflection

When a ray of light reflects off a surface (such as a mirror), its new direction depends on only the angle of incidence. The law of reflection states that the angle of incidence on a reflecting basic surface is equal to the angle of reflection. This is discussed in further detail in Module 1-3, *Basic Geometrical Optics*.

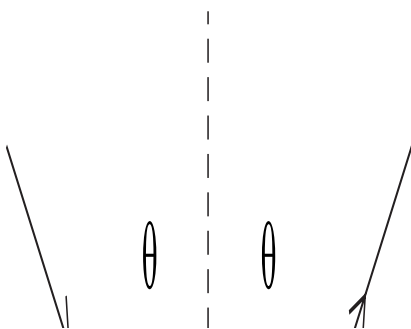

Law of reflection: Angle of incidence = Angle of reflection

Refraction

When a ray of light passes from one medium to another, it changes direction (bends) at the interface because of the difference in speed of the wave in the media. The ratio of this speed difference is called the **index of refraction** (n). The ratio of the indices of refraction and the direction of the two rays of light for the two media are expressed in Snell's law as shown in Figure 1-8 and Equation 1-6.

$$\frac{n_2}{n_1} = \frac{\sin \theta}{\sin \phi} \tag{1-6}$$

where n_1 and n_2 are the indices of refraction for the two media

θ is the angle of incidence

ϕ is the angle of refraction.

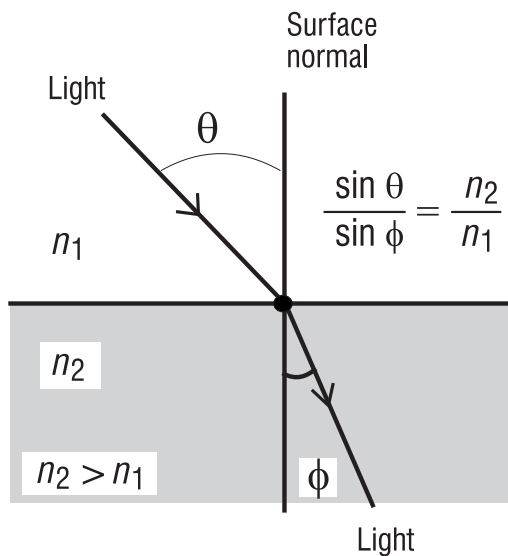

Figure 1-8 *Refraction and Snell's law*

Diffraction

Conclusive evidence of the correctness of a wave model came with the explanation of observed diffraction and interference. When light passes an obstacle, the shadow is not precise and sharp as geometrical ray theory would predict, but rather diffracted a little into the dark region behind the obstacle, thus giving the shadow a fuzzy edge. This property of light that causes it to spread out as it travels by sharp edges or through tiny holes can be explained by light having wavelike properties. Diffraction is predicted from Huygens' principle. In Figure 1-9, a wave is incident on a barrier from the left. The barrier has a slit. Every point on the incident wave front that arrives at the slit can be viewed as the site of an expanding spherical wavelet. For apertures that are small compared to the wavelength, the aperture becomes like a source and spherical waves result. As the slit width d increases, the diffracted wave becomes more and more like the incident plane wave except for the edges at the shadow.

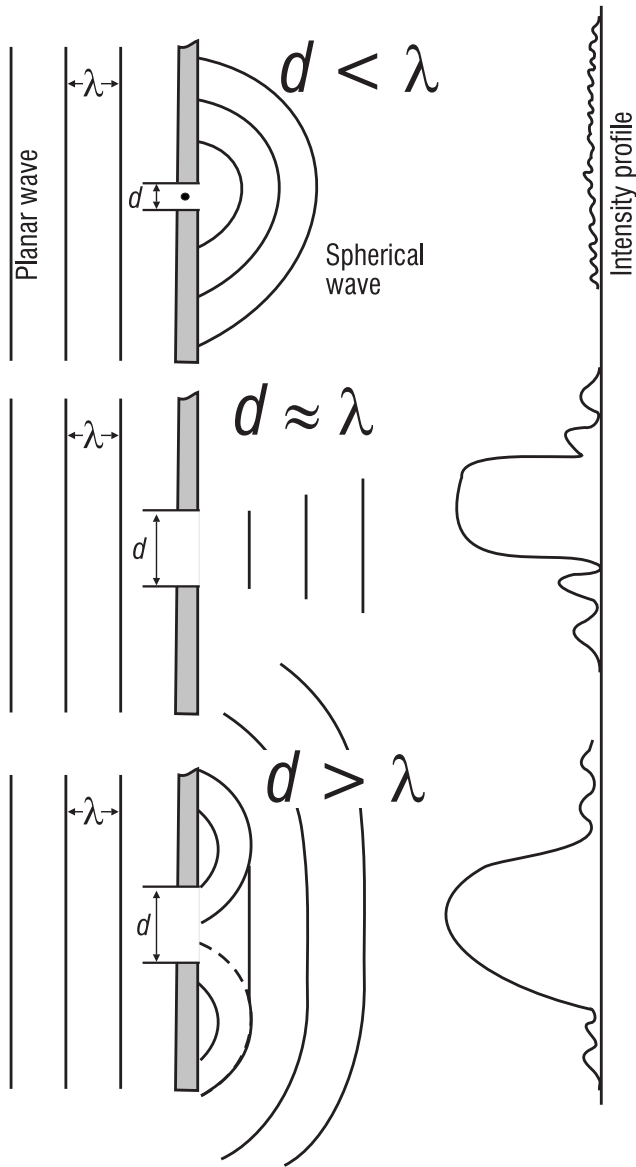

Figure 1-9 Diffraction of waves through slits of differing size

Interference

The first definitive demonstration of the wavelike nature of light was the classical two-slit experiment performed by Thomas Young in 1801. The two slits are very small compared to their separation distance. Thus, each slit produces diffracted spherical waves that overlap as they expand into the space to the right of the barrier. When they overlap, they interfere with each other, producing regions of mutually reinforcing waves. These appear on the screen as regions of maximum intensity. Between adjacent maxima is a region of minimum intensity. See Figure 1-10. The resulting pattern on the screen shows where constructive interference occurs (maxima, labeled B) and where destructive interference occurs (minima, labeled D). The experimental layout shown in Figure 1-10 can be used in practice to measure the wavelength of light. This experiment is covered with more rigor in Module 1-4, *Basic Physical Optics*.

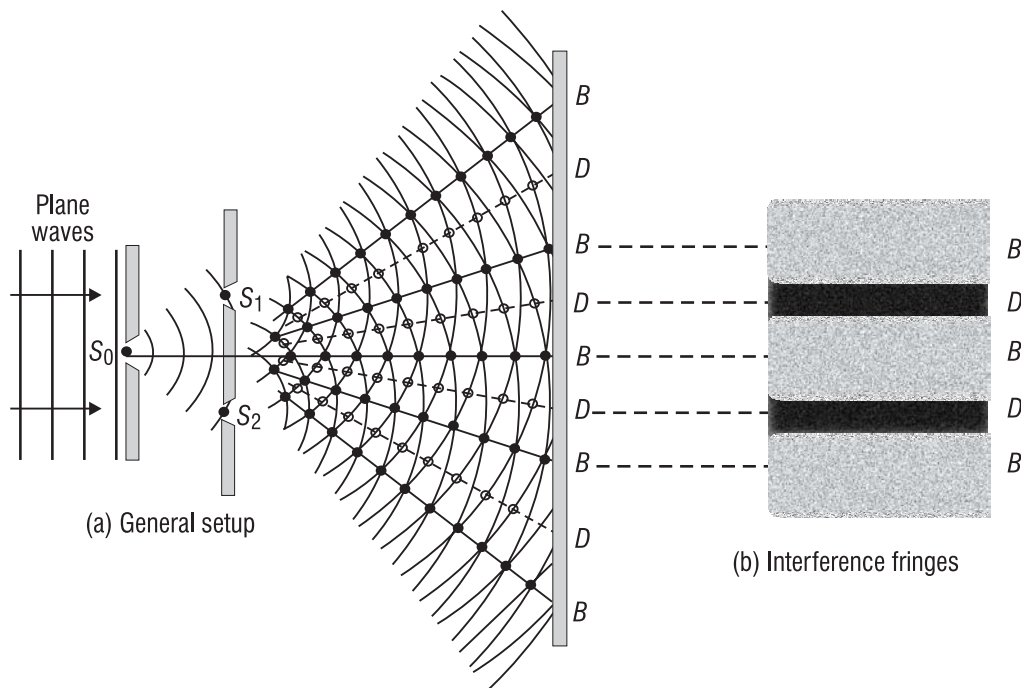

Figure 1-10 *Classic double-slit experiment*

The Electromagnetic Spectrum

All electromagnetic radiation has similar wavelike properties differing only in wavelength. Electromagnetic waves range in wavelength from very long (e.g., electric power line radiation at 60 Hz) to very short (e.g., gamma ray radiation). This entire range is called the **electromagnetic spectrum**. The spectrum shown in Figure 1-11 is divided by the practical applications for given ranges of frequencies that are set through convention by the sources and detection devices.

Of primary interest to photonics is the region from infrared to ultraviolet. However, each regime has some utility. Rotating generators and power lines generate low-frequency waves. These wavelengths are on the order of 10^5 to 10^8 meters. Heinrich Hertz produced radio waves in a very useful region of wavelengths ranging from 0.3 to 10^5 meters. Television and radio broadcasting bands are found in lower wavelengths. The microwave regime ranges from 0.01 to 0.3 meter and provides the radar and satellite communication bands. The infrared region, from 1 μm to 30 μm , was first detected by Sir William Herschel in 1800. This region is subdivided into five regions: very near (1–3 μm), near (3–5 μm), mid (5–6 μm), far (6–15 μm), and very long (15–30 μm) infrared. Just as the ear cannot hear above or below certain frequencies, the human eye cannot detect light outside a small range of wavelengths (0.76–0.49 μm). The ultraviolet region is a higher-energy region discovered by Johann Ritter. It triggers many chemical reactions and is what ionizes the upper atmosphere, creating the ionosphere. Wilhelm Röntgen discovered the X-ray regime in 1895. Its wavelength ranges from 10^{-8} to 10^{-11} meters. With its high energy, it can penetrate flesh and provide an image of higher-density material such as bones. Gamma rays represent the smallest wavelength (less than 10^{-13} meter). They exhibit

NATURE AND PROPERTIES OF LIGHT

particle-like properties with great energy and are emitted by the sun, linear and particle beam accelerators, and nuclear processes.

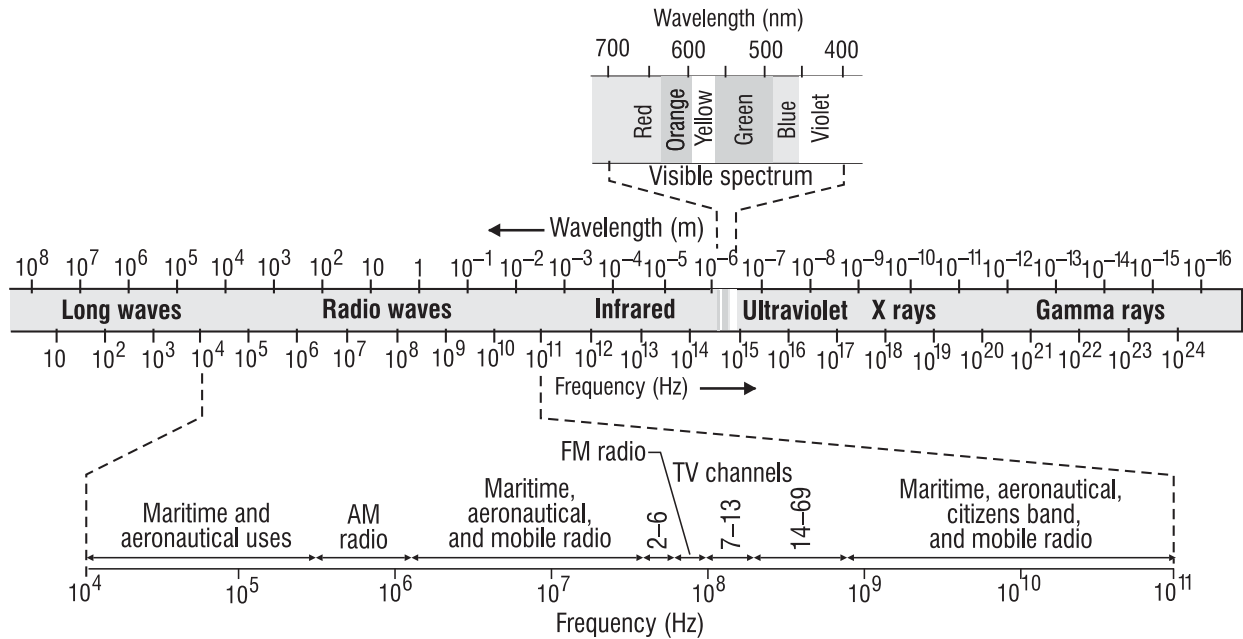

Figure 1-11 *Electromagnetic spectrum*

White light is a mixture of light of different colors. Each of these colors has a different wavelength and, when passed through a transparent medium, refracts differently. Thus, a prism can separate white light into its component colors, as shown in Figure 1-12.

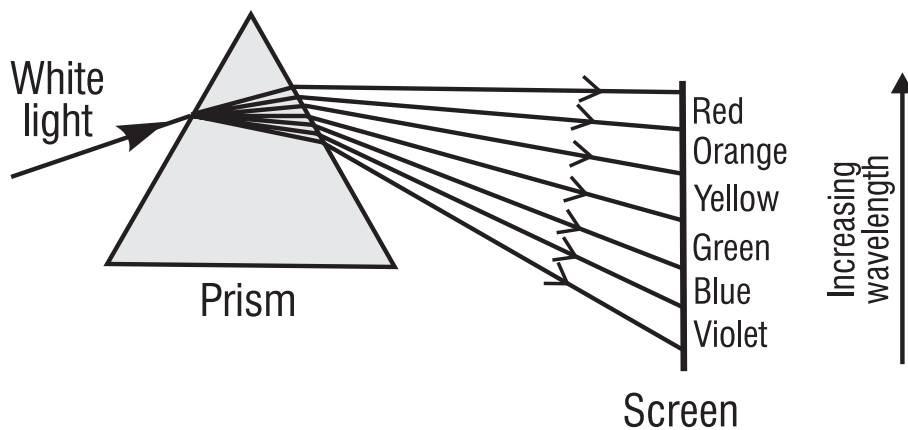

Figure 1-12 *Separation of light into component colors*

The colors displayed in visible light are categorized by wavelength. Table 1-2 gives the wavelengths of these colors. An arrangement showing the different components of light, with the wavelengths of the components in order, is called the spectrum of the light.

Table 1-2: Visible Spectrum Wavelengths

Color	Wavelength Band (μm)	Representative wavelength (μm)
Extreme violet	0.39–0.41	0.40
Violet	0.39–0.45	0.43
Dark blue	0.45–0.48	0.47
Light blue	0.48–0.50	0.49
Green	0.50–0.55	0.53
Yellow-green	0.55–0.57	0.56
Yellow	0.57–0.58	0.58
Orange	0.58–0.62	0.60
Red	0.62–0.70	0.64
Deep red	0.70–0.76	0.72

Spectra of Light Sources

The sources of electromagnetic radiation are many and varied. Usually sources are divided into two categories, natural and man-made. Examples of natural sources of radiation are the sun, observable stars, radio stars, lightning, and, in fact, any body that exists at a temperature over absolute zero. Some of the man-made sources of radiation are incandescent and fluorescent lights, heaters, lasers, masers, radio and television antennas, radars, and X-ray tubes.

Two types of spectra are important in photonics: the emission and the absorption spectra. An emission spectrum is from light emitted by a source. An absorption spectrum is from light that has passed through an absorbing medium.

All materials with temperatures above absolute zero emit electromagnetic radiation. Every atom and molecule has its own characteristic set of spectral lines. The understanding of the wavelength and energy that produce the spectral “fingerprint” is built on an explanation of the atomic and molecular structure. The line spectra observed early in the scientific age led to significant understanding of the nature of atoms. They even led to the development of modern quantum theory, which says that light emitted by an atom or molecule has a discrete wavelength, corresponding to a specific energy-level change within the atom or molecule.

These fingerprints can have any combination of spectral lines, bands, and continuums. Atoms changing states produce visible and ultraviolet radiation. Molecules changing vibrational and rotational states produce infrared radiation. For dense materials, many energy states are available; thus emission and absorption bands cover broad regimes for solids and liquids. For a less dense gas, the spectral bands are much narrower.

To observe a line or band spectrum, a light is passed through a slit. The image of this slit is then refracted by a prism or diffracted by a grating, based on the constituent wavelengths of the light. This is recorded on film or a spectrograph. The lines relate back to the atomic structure and the unique energy-level changes. Spectroscopy is the science that analyzes line spectra and identifies constituents of materials.

NATURE AND PROPERTIES OF LIGHT

When atoms are close to each other, their electrons interact and the energy levels split. In a solid, there are so many levels that a continuous range of frequencies can be emitted or absorbed. Hot, dense materials emit *continuous spectra* containing bands of frequencies.

Atomic Structure

All matter is made up of atoms. An atom is the smallest unit that retains the characteristics of a chemical element. It consists of a positive nucleus surrounded by negative electrons arranged in distinct energy shells designated *K* through *O*, as shown in Figure 1-13. The notation *K*(2) indicates that the *K*-shell is complete when it has 2 electrons. Similarly, *L*(8) indicates that 8 electrons complete the *L*-shell, and *M*(18) indicates that 18 electrons complete the *M*-shell.

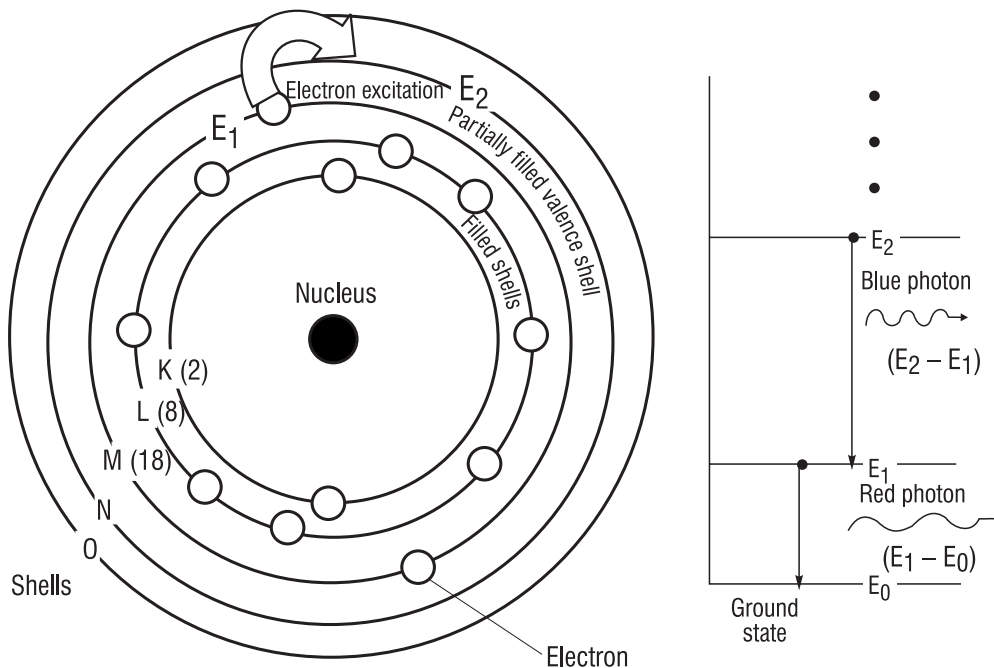

Figure 1-13 Atomic model

We model the energy of an atom with the electrons. When all the electrons are in an unexcited, or ground, state, the atom is assumed to be at its lowest energy level. When the atom absorbs energy, electrons can be “excited” and moved into higher-energy shells. As electrons move from one shell to another, unique amounts, or quanta, of energy are absorbed or emitted. This is how an atom can absorb or emit light. The light’s unique energy quanta are dependent on the electronic structure of the atom.

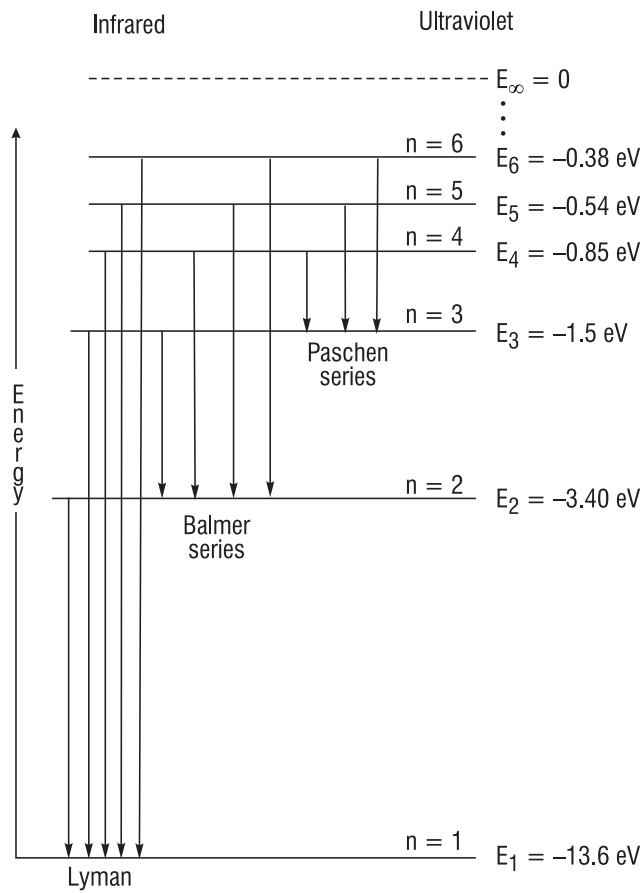

Figure 1-14 Energy-level diagram for a hydrogen atom

An atomic energy-level diagram shows the unique electron energies available in a given atom. An energy-level diagram for hydrogen is shown in Figure 1-14. Hydrogen has only one electron, and it can exist in only one of the energy levels shown at a time. The lowest level, E_1 , is the ground state. Energy must be added to the atom for the electron to move to a higher level. Note that energy levels range from a value of -13.6 eV (electron volts) for the lowest energy level ($n = 1$) to a value of 0 eV for the very highest energy level ($n = \infty$)—when the electron breaks free from the atom.

Suppose a hydrogen atom is in an excited state, say, the $n = 3$ level. The atom can make a transition to the ground state by emitting a photon. The energy of the photon equals the change in energy of the atom, as given by Equation 1-7.

$$\begin{aligned}
 E_{\text{photon}} &= E_3 - E_1 \\
 &= -1.51 \text{ eV} - (-13.6 \text{ eV}) \\
 &= 12.09 \text{ eV}
 \end{aligned}
 \tag{1-7}$$

The atom can also absorb photons whose energies exactly match differences between electron energy levels. For example, a hydrogen atom in the ground state can absorb a photon whose energy is 12.09 eV . The electron in the atom will move from energy level E_1 to energy level E_3 .

Molecular Structure

Molecules in gases or liquids can also absorb electromagnetic radiation. The photon energy must match a discrete rotational or vibrational energy level of the molecule. In solids, absorption is more complex, generally resulting from vibrational energy changes.

Blackbody Radiation

The first step toward developing an understanding of *blackbody radiation* is to describe the relationships between temperature, wavelength, and energy emitted by an ideal thermal radiator (blackbody). Based on our everyday observations, we know that bodies at different temperatures emit radiation (heat energy) of different wavelengths or colors. For example, the wires in a heater begin to glow red when heated.

Blackbody radiation is the theoretical maximum radiation expected for temperature-related thermal self-radiation. This radiation can have a peak energy distribution in the infrared, visible, or ultraviolet region of the electromagnetic spectrum. The hotter the emitter, the more energy emitted and the shorter the wavelength. An object at room temperature has its peak radiation in the infrared while the sun has its peak in the visible region.

The equations for calculating radiation based on temperature use the Kelvin temperature scale. (Be sure to use the Kelvin scale for all calculations.) The conversions between the different temperature scales are provided in Equations 1-8 and 1-9.

Fahrenheit (F) to Celsius (C)	$^{\circ}\text{C} = 5/9 (^{\circ}\text{F} - 32)$	(1-8)
-------------------------------	--	-------

Celsius (C) to Kelvin (K)	$\text{K} = ^{\circ}\text{C} + 273.15$	(1-9)
---------------------------	--	-------

Example 1-5

Convert the following Fahrenheit temperatures to degrees Celsius and Kelvin: 212, 100, 32, 0, -100, -434.

Solution:

Use Equations 1-8 and 1-9 to complete Table 1-3 with the correct temperatures.

Table 1-3: Temperature Conversion

	Fahrenheit ($^{\circ}\text{F}$)	Celsius ($^{\circ}\text{C}$)	Kelvin (K)
Boiling water	212	100	373
	100	38	311
Freezing water	32	0	273
	0	-18	255
	-100	-73	200
Absolute zero	-434	-273	0

A waveband is a portion of the electromagnetic spectrum between defined upper and lower wavelengths. The energy radiated by a blackbody in a given waveband is the sum of all energies radiated at the wavelengths within the band. The rate of energy radiation is the power radiated. You can also add the power over all emitted wavelengths to find the total power radiated by a blackbody. For a blackbody at temperature T , the power radiated per unit surface area of the radiator is given by the Stefan-Boltzmann law in Equation 1-10.

$$W_s = \sigma_s T^4 \text{ watts/m}^2 \quad (1-10)$$

where $\sigma_s = 5.67 \times 10^{-8} \text{ watts/m}^2 \cdot \text{K}^4$ (Stefan-Boltzmann constant)
 T = Temperature (K)

The power per unit area, W_s , is called the emitted radiant flux density. A graybody is one that does not emit as a perfect “blackbody” but at a fraction of the theoretical maximum of a blackbody. The blackbody’s emitted radiant flux density is reduced by a factor called the emissivity. The emissivity (ϵ) is dependent on the material emitting and is less than 1. Thus, for a graybody the emitted radiant flux density is expressed in Equation 1-11.

$$W_s = \epsilon \sigma_s T^4 \text{ watts/m}^2 \quad (1-11)$$

Example 1-6

Calculate the radiant flux density emitted by a graybody (emissivity = 0.7) at room temperature (82°F).

Solution:

First we must convert 82°F to Kelvin. This is 301 K. We then use Equation 1-11 and plug in the numbers.

$$W_s = (0.7) \left(5.67 \times 10^{-8} \frac{\text{watts}}{\text{m}^2 \text{ K}^4} \right) (301 \text{ K})^4 = 325.5 \text{ W/m}^2$$

Spectral distribution

The radiation emitted by a blackbody is distributed over wavelength. The quantity W_λ is called the spectral flux density. It is defined so that $W_\lambda \Delta\lambda$ is the power radiated per unit area of surface for wavelengths in the waveband $\Delta\lambda$ (between λ and $\lambda + \Delta\lambda$). In 1900, Max Planck developed a formula that fits experimental measurements of W_λ extremely well. Planck’s radiation formula is given by Equation 1-12.

NATURE AND PROPERTIES OF LIGHT

$$W_{\lambda} = \frac{C_1}{\lambda^5} \frac{1}{e^{\frac{C_2}{\lambda T}} - 1} \quad (1-12)$$

where λ = wavelength (m)

T = blackbody temperature (K)

$$C_1 = 2 \pi c^2 h = 3.75 \times 10^{-16} \text{ W}\cdot\text{m}^2$$

$$C_2 = hc/k = 1.44 \times 10^{-4} \text{ m}\cdot\text{K}$$

c = speed of light = 3.00×10^8 m/s

h = Planck's constant = 6.626×10^{-34} J·s

k = Boltzmann's constant = 1.38×10^{-23} J/K

The blackbody spectral flux density from Planck's formula is plotted in Figure 1-15 for five blackbody temperatures. The wavelengths are plotted in units of microns. Notice that the axes are logarithmic.

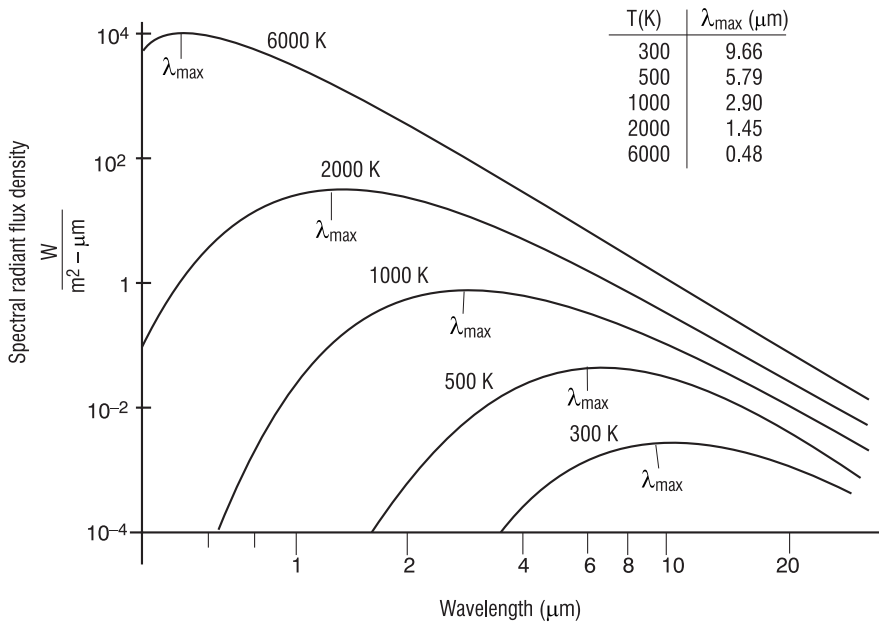

Figure 1-15 Spectral radiant blackbody flux density distributions at various temperatures

Wien's displacement law

The spectral distribution for each blackbody temperature has a maximum, or peak, emission wavelength. This maximum wavelength is related to the blackbody temperature. The relationship is given by Wien's displacement law:

$$\lambda_{\max} T = 2.898 \times 10^{-3} \text{ m}\cdot\text{K} \quad (1-13)$$

Wien's displacement law predicts that the peak wavelength decreases in value as the temperature of the blackbody increases.

Example 1-7

Calculate the apparent blackbody temperature of the sun. If it is observed that the peak spectral radiant flux density of the sun is near 490 nm, what is its effective blackbody temperature?

Solution:

By applying Wien's displacement law and solving for T , we can find the sun's effective temperature.

$$\lambda_{\max} T = 2.898 \times 10^{-3} \text{ m} \cdot \text{K}$$

$$T = \frac{2.898 \times 10^{-3} \text{ m} \cdot \text{K}}{490 \times 10^{-9} \text{ m}} = 5914 \text{ K}$$

This equation allows the choice of the wavelength most advantageous for detectors given an expected target temperature.

Interactions of Light with Matter

When light travels through a medium, it interacts with the medium. The important interactions are absorption and scattering.

Absorption

Absorption is a transfer of energy from the electromagnetic wave to the atoms or molecules of the medium. Energy transferred to an atom can excite electrons to higher energy states. Energy transferred to a molecule can excite vibrations or rotations. The wavelengths of light that can excite these energy states depend on the energy-level structures and therefore on the types of atoms and molecules contained in the medium. The spectrum of the light after passing through a medium appears to have certain wavelengths removed because they have been absorbed. This is called an absorption spectrum.

Selective absorption is also the basis for objects having color. A red apple is red because it absorbs the other colors of the visible spectrum and reflects only red light.

Scattering

Scattering is the redirection of light caused by the light's interaction with matter. The scattered electromagnetic radiation may have the same or longer wavelength (lower energy) as the incident radiation, and it may have a different polarization.

If the dimensions of the scatterer are much smaller than the wavelength of light, like a molecule, for example, the scatterer can absorb the incident light and quickly reemit the light in a different direction. If the reemitted light has the same wavelength as the incident light, the process is called *Rayleigh scattering*. If the reemitted light has a longer wavelength, the molecule is left in an excited state, and the process is called *Raman scattering*. In Raman scattering, secondary photons of longer wavelength are emitted when the molecule returns to the ground state.

NATURE AND PROPERTIES OF LIGHT

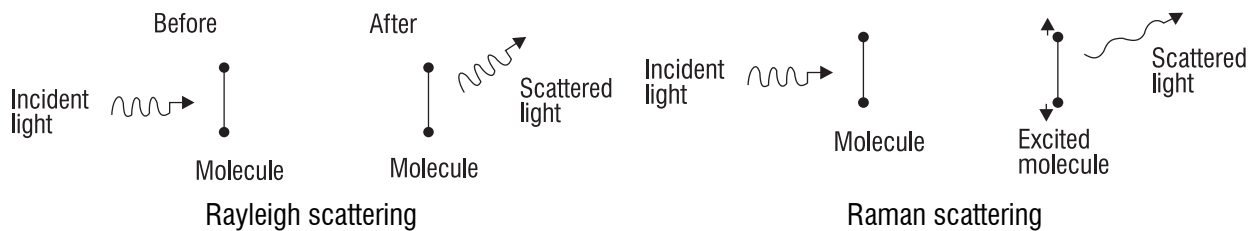

Figure 1-16 Rayleigh and Raman scattering

Air molecules (O_2 and N_2) are Rayleigh scatterers of visible light and are more effective at scattering shorter wavelengths (blue and violet). Can you use this information to explain why, on a clear day, the sky looks blue?

If the scatterer is similar in size to—or is much larger than—the wavelength of light, matching energy levels is not important. All wavelengths are equally scattered. This process is called *Mie scattering*. Water droplets effectively scatter all wavelengths of visible light in all directions. Can you use this information to explain the color of a cloud?

Laboratories

Purpose

Examine basic properties of light such as the following:

- speed
- wavelength
- color spectrum of visible light
- polarization

Laboratory 1.1A—Finding the Speed of Red Light in Optical-Grade Plastic

Theory

The speed of light in a vacuum, c , is exactly 299,792,485 m/s. Current physical theory asserts that nothing in our universe can have a speed greater than c . When light, or any electromagnetic wave, moves in any other medium it will have a speed less than c . In general, the speed of light through a medium depends upon both the medium and the wavelength of the light. The object of this experiment is to use the definition of index of refraction and Snell's law to determine the speed of red light in optical plastic.

Key Definitions and Relationships

1. The index of refraction for any medium, n , is defined as: $n_i = \frac{c}{v_i}$ where v_i is the velocity of light in medium, i .
2. Snell's law $\frac{n_1}{n_2} = \frac{\sin \theta_2}{\sin \theta_1}$
3. The speed of light in vacuum and air is the same to an accuracy of six significant figures, so we will use $n_{air} = 1.00000$.

Equipment

1. Laser, either a red laser pointer or a Class I or II HeNe laser
2. Laboratory stand and clamps to hold laser and gratings
3. Plastic optical block, approximately 8 cm \times 6 cm \times 2 cm

NATURE AND PROPERTIES OF LIGHT

4. $8\frac{1}{2}'' \times 14''$ white paper
5. Masking tape
6. Meterstick
7. Protractor

Procedure

1. Tape a legal-size sheet of blank white paper to the tabletop. Tape a laser pointer on the left side so the beam is directed left to right across the paper.

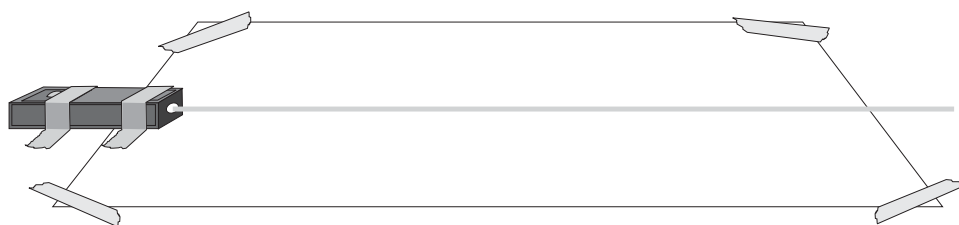

2. Turn on the laser. Hold a pencil in a vertical position at the right edge of the paper where the laser beam hits the center of the pencil. Mark the paper with a small dot or dash. See sketch.

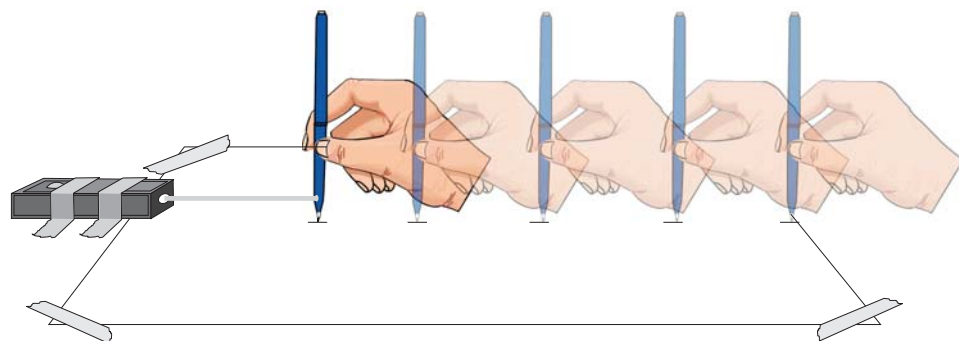

Move the pencil directly left one or two inches and repeat. Continue until you have five or six marks extending left to right across the paper. Draw a “best-fit” straight line through the marks. Label the point at the left end of this line point *O*. See sketch.

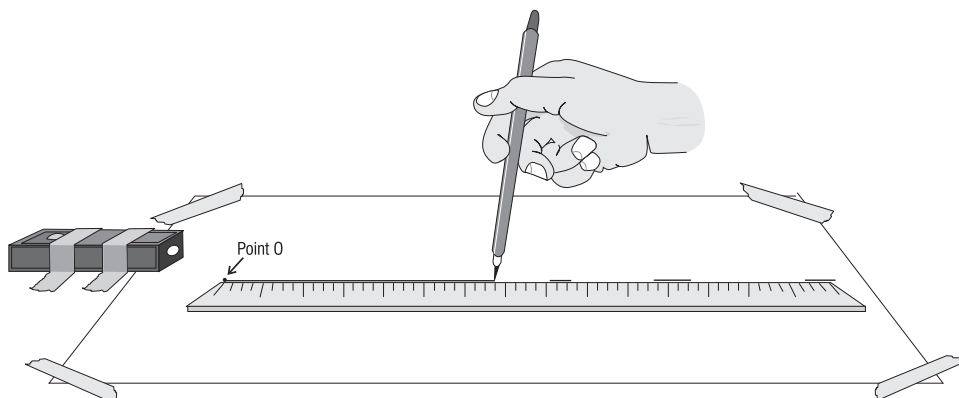

- Place the plastic block with the large surface down. The left face of the block should intersect the line on the paper at a 40- to 50-degree angle, and the laser beam should hit the left face about 1 cm from its lower left corner. Hold the block firmly in place and draw an outline of the block on the paper. See sketch.

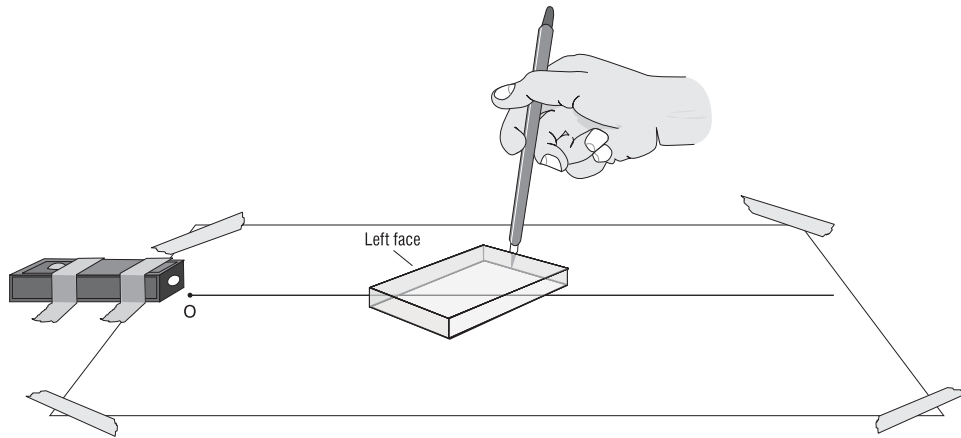

- Turn on the laser. The beam is refracted by the block and should exit the block through the right face. Move your pencil along the right edge of the paper until you find the beam. Mark the location of this exit beam at five or six places on the paper just as you did for the straight beam in step 2. See sketch.

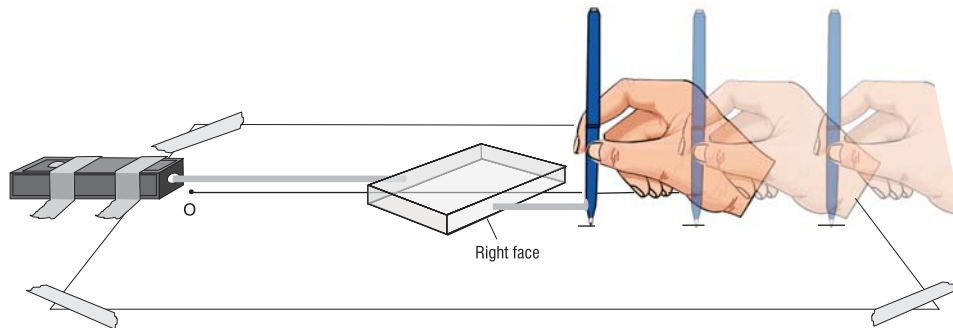

- Remove the plastic block. Draw a best-fit straight line through the marks along the exit beam path. See sketch.

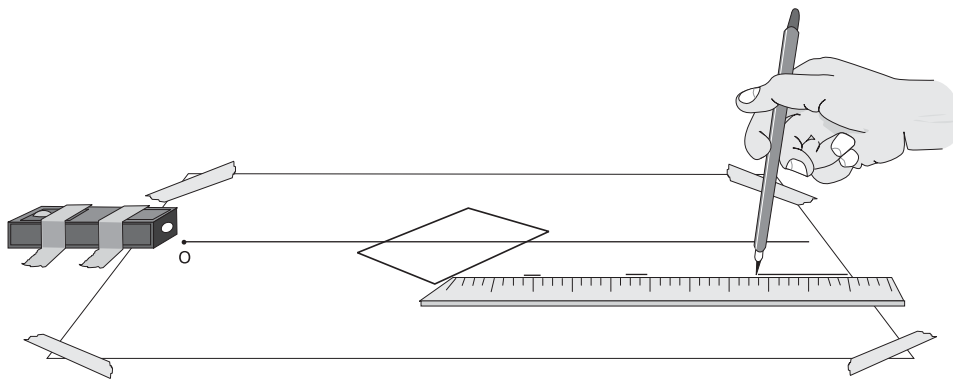

NATURE AND PROPERTIES OF LIGHT

Mark the right end of the line as point D . Extend this line to the left until it intersects the line marking the lower edge of the plastic block. This is the point where the beam left the block. Mark this point as point B . Mark the point where the incident beam hit the left face of the block as point A . Connect points A and B with the line segment AB . See sketch.

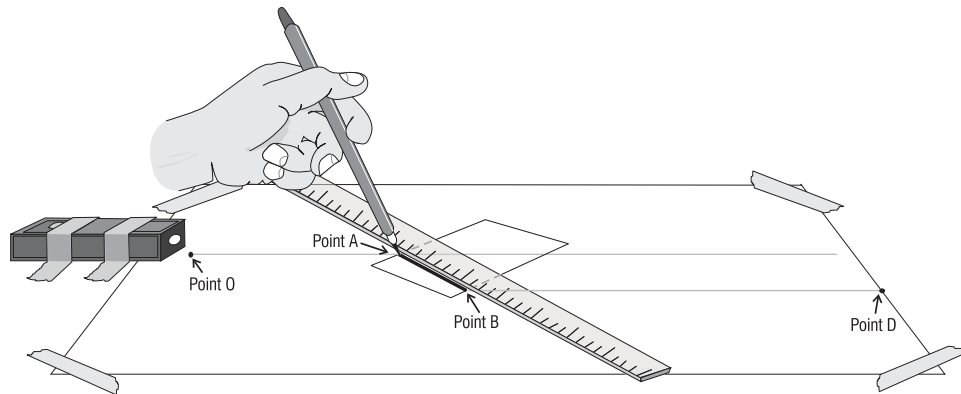

Note: The line segment OA describes the path of the laser beam that is incident on the block. The line segment AB describes the path of the refracted beam through the block. The segment BD describes the beam's path after it exits the block.

- Use the protractor to draw a line through point A that is perpendicular to the left face of the block. Draw another line through point B that is perpendicular to the right face of the block. See sketch.

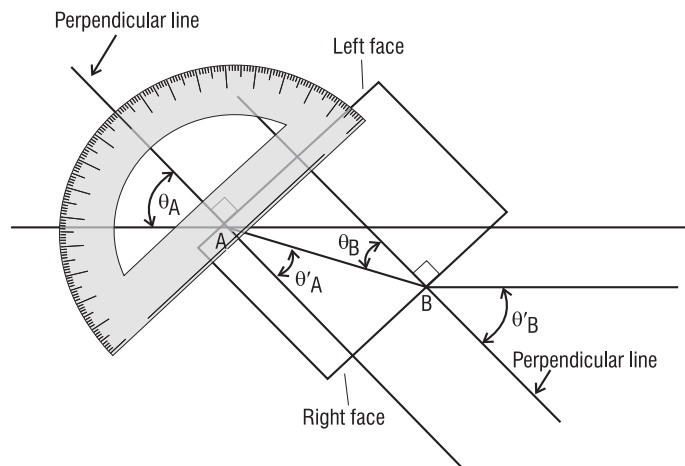

- Measure and record the angle θ_A between the incident beam and the normal line at the left face of the block (point A). Do the same for the refracted beam at this face. This is angle θ'_A . See sketch.
- Measure the angle between the normal line and the incident and refracted (exit) beam at the right face of the block (point B). Label these as θ_B and θ'_B . See sketch.
- Using θ_A and θ'_A , use Snell's law to find the ratio $\frac{n_{air}}{n_{plastic}}$ at the left interface between air and plastic.

10. Using θ_B and θ_B' , use Snell's law to find the ratio $\frac{n_{plastic}}{n_{air}}$ at the right interface between plastic and air.
11. The index of refraction of air, n_{air} , has a value of 1.00000. Use this and the results of steps 9 and 10 to find the numerical value of $n_{plastic}$ from your measurements at A and at B . Average the two values to determine your final estimate of $n_{plastic}$.
12. Use the definition of index of refraction and the known value of speed c in a vacuum to calculate the speed of light in the plastic block.

Laboratory 1.1B—Determining the Wavelength of Red Light

Theory

When a beam of light is incident on a diffraction grating, part of the light will pass straight through. Part of the light is diffracted to paths that diverge at different angles on both sides of the original path. The angle θ at which the light diverges is related to the wavelength and spacing of the lines on the grating. The relationship is described by

$$m\lambda = d \sin\theta_m \quad \text{where } \lambda \text{ is the wavelength of the incident light in meters, } d \text{ is the spacing between lines on the grating in meters, } m \text{ is an integer that takes on the values } 0, 1, 2, \dots, \text{ and } \theta_m \text{ is the diffraction angle for a particular diffraction order } m.$$

If the diffraction angle θ_m can be measured for a particular order m and the grating spacing d is known, the wavelength of the light can be calculated.

Equipment

1. Laser, either a red laser pointer or a Class I or II HeNe laser
2. Laboratory stand and clamps to hold laser and gratings
3. Transmission grating with 300 to 800 lines/mm
4. $8\frac{1}{2}'' \times 14''$ white paper
5. Masking tape
6. Meterstick

Procedure

1. Position the laser so the beam goes straight down through the grating—perpendicular to the grating surface—and onto the white paper. There it produces a center spot with diffracted spots on both sides as shown in the sketch.

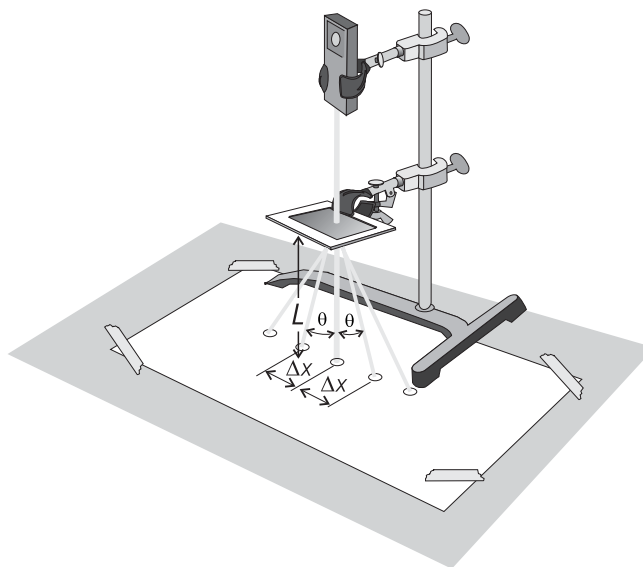

2. Measure the vertical distance from the grating to the paper. Record this as L .
3. Measure the distances from the center spot to the first diffracted spots on both sides. Average these two distances and record the average as Δx . For these nearest diffracted spots, $m = 1$.
4. Calculate the diffraction angle using $\theta_1 = \tan^{-1}\left(\frac{\Delta x}{L}\right)$
5. Calculate the wavelength of the red laser light using this first-order diffraction angle, θ_1 where $m = 1$. The equation is then

$$\lambda = \frac{d \sin \theta_1}{1}$$

Laboratory 1.1C—The Spectrum of Colored Light

Equipment

1. Flashlight with focusing capability, similar to the Mini-Maglight series
2. Laboratory stand and clamps to hold laser or flashlight and grating
3. Transmission grating with 300 to 800 lines/mm
4. Red, green, blue, purple, yellow, and orange filters
5. $8\frac{1}{2}'' \times 14''$ white paper
6. Masking tape

Procedure

Part 1. The Spectrum of White Light

1. Mount the flashlight in a clamp on the stand with the beam projected straight down onto a sheet of white paper.
2. Mount the diffraction grating in another clamp and position it four or five inches below the flashlight. Focus the light perpendicularly onto the grating surface. See sketch.
3. Move the grating, and flashlight if necessary, up or down until you see clearly both the light transmitted straight down through the grating, forming a white spot on the paper, and the first order spectrum of colors. See sketch.

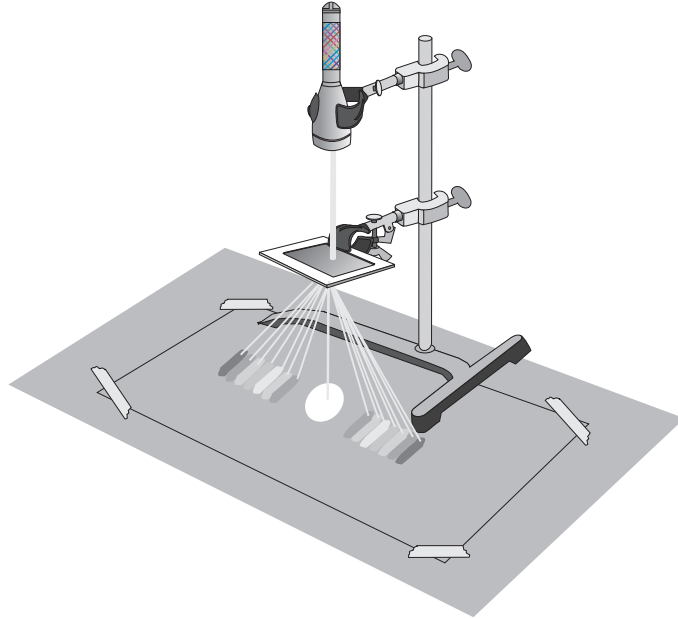

4. Draw lines through each color you can identify in the spectrum, and label each line with its color.

Part 2. The Components of Different Colors of Light

5. Hold a red transmission filter between the flashlight and the grating. What is the color of the center spot where light is transmitted straight through the grating? List all the colors that you can clearly identify in the diffracted spectrum on either side of the center spot.
6. Replace the red filter with the other filters in this order: green, blue, purple, yellow, and orange. For each filter list all the colors you can identify in the diffracted spectrum of the light formed on either side of the center spot.
7. Answer the following questions with complete sentences.
 - (a) Why are red, green, and blue primary colors?
 - (b) What colors of light must be combined to make purple light?
 - (c) What colors of light must be combined to make yellow light?
 - (d) How can a color TV produce any color it needs when it has only red, green, and blue color guns?

Laboratory 1.1D—*The Polarization of Light*

Equipment

1. Flashlight with focusing capability, similar to the Mini-Maglight series
2. Laboratory stand and clamps to hold laser or flashlight and grating
3. Two polarizing filters
4. Microscope slide or similar thin, flat glass plate
5. 8½" × 14" white paper
6. Masking tape

Procedure

Part 1. Polarizers and Analyzers

1. Clamp a flashlight with the beam projected horizontally about five feet above the floor. It should be arranged so that it is easy to look directly into the light when you are five or six feet from the flashlight.

Hold one polarizer at arm's length in front of you and look at the light through the polarizer. The light you see is now polarized in the preferred direction of the filter.

2. Hold a second polarizing filter (analyzer) with your other hand. Place it between you and the first filter. Rotate the second filter about the axis of the light beam. Notice the change in brightness of the light passing through both filters and reaching you.
3. What can you say about the relation between the polarizing direction of the two filters when the light transmitted has its maximum brightness?
4. What can you say about the relation between the polarizing direction of the two filters when the light transmitted has its minimum brightness?

Part 2. Polarization by Reflection

5. Clamp the flashlight so the center of the lens is 5 inches above the table and the light beam is focused on a spot eight inches horizontally from the flashlight. Place a microscope slide on the table at the position of the focused spot. See sketch.

6. Position yourself in line with the microscope slide and the flashlight. Move until you can see the reflection of the flashlight from the slide. See sketch.

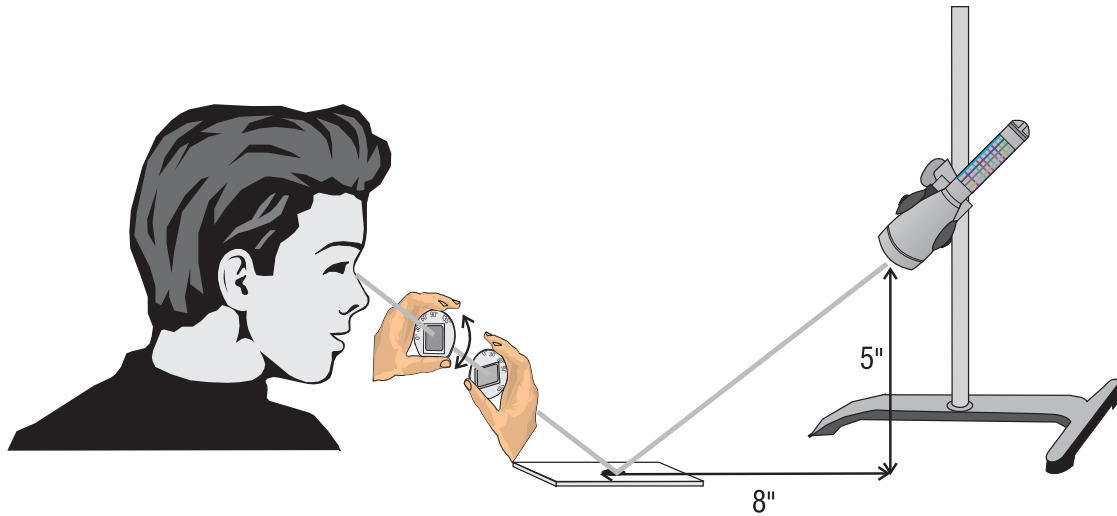

7. Hold a polarizing filter so you can see the reflection through the filter. Rotate the filter about the axis of the reflected beam. See sketch. What do you observe about the brightness of the reflection as you rotate the filter?

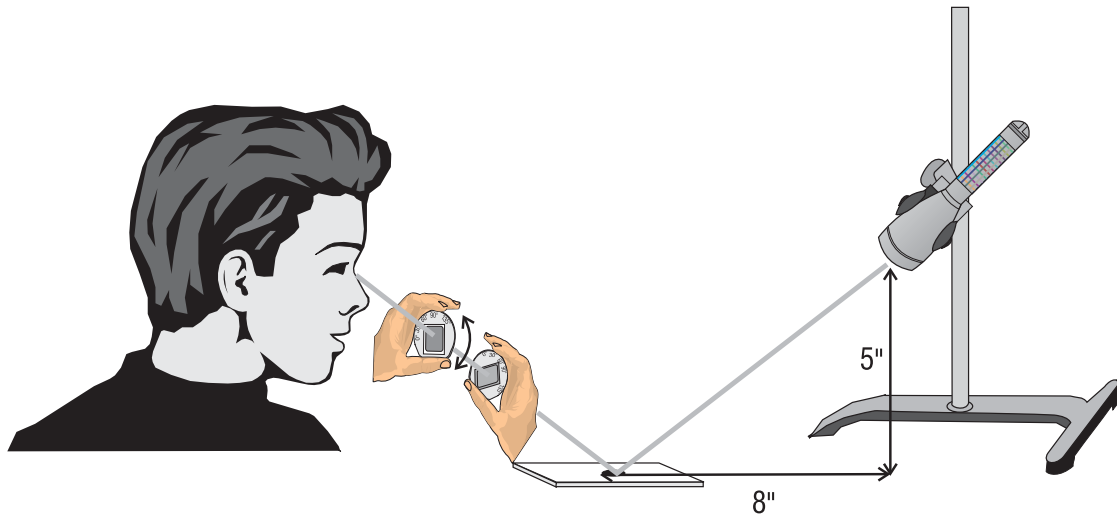

8. How does the reflection from the glass affect the properties of the reflected light?

Problem Exercises/Questions

1. Discuss some of opportunities for technicians in the photonics field.
2. Define the following properties of light:
 - a. Speed
 - b. Frequency
 - c. Wavelength
 - d. Energy
3. Discuss the dual nature of light wave versus photon and give examples of each.
4. Describe in a short paragraph the electromagnetic spectrum with a diagram of the wavelength regions and typical applications in those regions.
5. An electron in a hydrogen atom is designated to have energy (relative to infinity) with
 - a. Any value
 - b. Any positive value
 - c. Any negative value
 - d. Only certain isolated values
6. Give the primary equations describing the relationships between temperature, wavelength, and energy emitted by a blackbody.
7. Address the mechanisms that affect light propagating in a medium and its transmission.
8. Which of the following light sources emits a continuous spectrum?
 - a. A neon light
 - b. A glowing coal
 - c. A mercury vapor lamp
 - d. Hot, thin interstellar gas
9. Which of the following colors corresponds to the longest wavelength?
 - a. Blue
 - b. Violet
 - c. Red
 - d. Green
10. List the six properties of wave motion.

Student Project

Create a presentation that educates others at the elementary school level about photonics and the uses of light.

Bibliography and Resources

Accetta/Schunder. *IR/EO System Handbook*. ERIM and SPIE Press.

Cobb, Vickie, Joshua Cobb, and Theo Cobb. *Light Action—Amazing Experiments with Optics*. Harper Collins Children’s Books, 1993.

Ford, Kenneth. *Basic Physics*. Walton, Massachusetts: Blaisdell Publishing Co., 1968.

Hecht, Jeff. *Optics Light for New Age*.

Jenkins and White. *Fundamentals of Optics*. New York: McGraw-Hill, 1976.

National Photonics Skills Standard for Technicians. Pittsfield, Massachusetts: Laurin Publishing Company, Inc., 1995.

Seyrafi, Khalil. *Electro-Optical Systems Analysis*. Los Angeles: Electro-Optical Research Company, 1985.

Laser As a Tool (Video) and *Career Encounters: Optics and Photonics* (Video). Washington, D.C.: Optical Society of America, Ph 202/223-8130, Fax 202/223-1096, E-mail <postmaster@osa.org>.

The Photonics Dictionary. www.laurin.com/DataCenter/Dictionary//CD/index.htm

Metric Prefixes

Prefix	Abbreviation	Power of Ten	Value
tera	T	10^{12}	thousand billion
giga	G	10^9	billion
mega	M	10^6	million
kilo	k	10^3	thousand
centi	c	10^{-2}	hundredth
milli	m	10^{-3}	thousandths
micro	μ	10^{-6}	millionth
nano	n	10^{-9}	billionth
pico	p	10^{-12}	thousand billionths